

SA Series

MODEL SA-VI

■ 대응 샹크 available shanks

HSK BT STT ST MT JT

■ 대응 기능 available functions

압축 compression 인장 tension 깊이 제어 depth control 레디얼 플로트 radial float 역전 self-reverse 클린트 coolant

◎ 모든 기계에 사용 가능

- 신축(伸縮)장치에 의한 동기 오차 흡수
- 좁은 공간용의 작은 디자인
- 탭 콜렛의 신속한 교환

◎ Designed for wide range of machine tools

- Synchro error compensation on tension and compression
- Short design for limited space
- Quick-change of tap collets

■ 조합표

combination chart	추천 콜렛 P17 matching collets P17
SA 412-VI	TC 412
SA1022-VI	TC1022

model ST-SA-VI (cylindrical parallel shank)

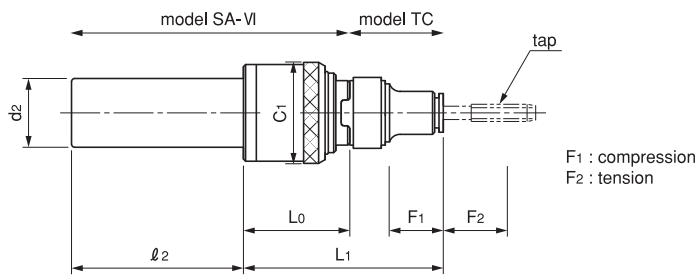

unit:mm

model	L0	L1	C1	F1	F2	ST shank		capacity	weight (kg)
						ℓ2	d2		
☆ ST20-SA 412-VI	93.0	49.5	47	6	8	60	20	M3~M16	0.51
ST25-SA 412-VI	93.0	49.5	47	6	8	75	25	M3~M16	0.64
ST32-SA 412-VI	93.0	49.5	47	6	8	80	32	M3~M16	0.86
ST32-SA1022-VI	140.0	75.0	64	8	10	80	32	M8~M27	1.47
☆ ST42-SA1022-VI	140.0	75.0	64	8	10	80	42	M8~M27	1.80

※ ☆의 형식은 수주 생산이기 때문에 납기까지 시간이 걸리는 경우가 있습니다.
 ※ Models marked with ☆ may require a longer delivery term because they are based on per-order production.



ST32-SA412-VI + TC412

model STT-SA-VI (Flatted cylindrical parallel shank for CNC lathes)

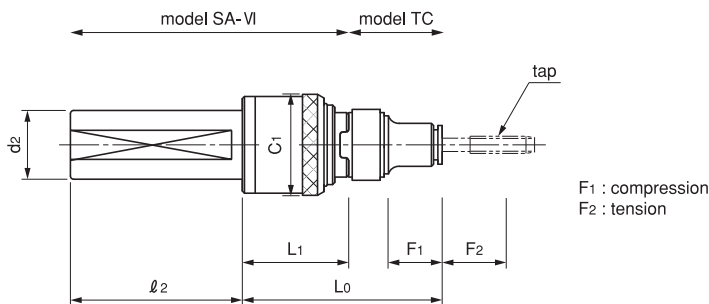

unit:mm

model	L0	L1	C1	F1	F2	STT shank		capacity	weight (kg)
						ℓ2	d2		
STT20-SA 412-VI	93.0	49.5	47	6	8	60	20	M3~M16	0.51
STT25-SA 412-VI	93.0	49.5	47	6	8	75	25	M3~M16	0.64
STT32-SA 412-VI	93.0	49.5	47	6	8	80	32	M3~M16	0.86
STT32-SA1022-VI	140.0	75.0	64	8	10	80	32	M8~M27	1.47
☆ STT40-SA1022-VI	140.0	75.0	64	8	10	80	40	M8~M27	1.73

※ ☆의 형식은 수주 생산이기 때문에 납기까지 시간이 걸리는 경우가 있습니다.
 ※ Models marked with ☆ may require a longer delivery term because they are based on per-order production.



STT32-SA412-VI + TC412