

# Deburring Holder, KATO

One Holder for Various Materials

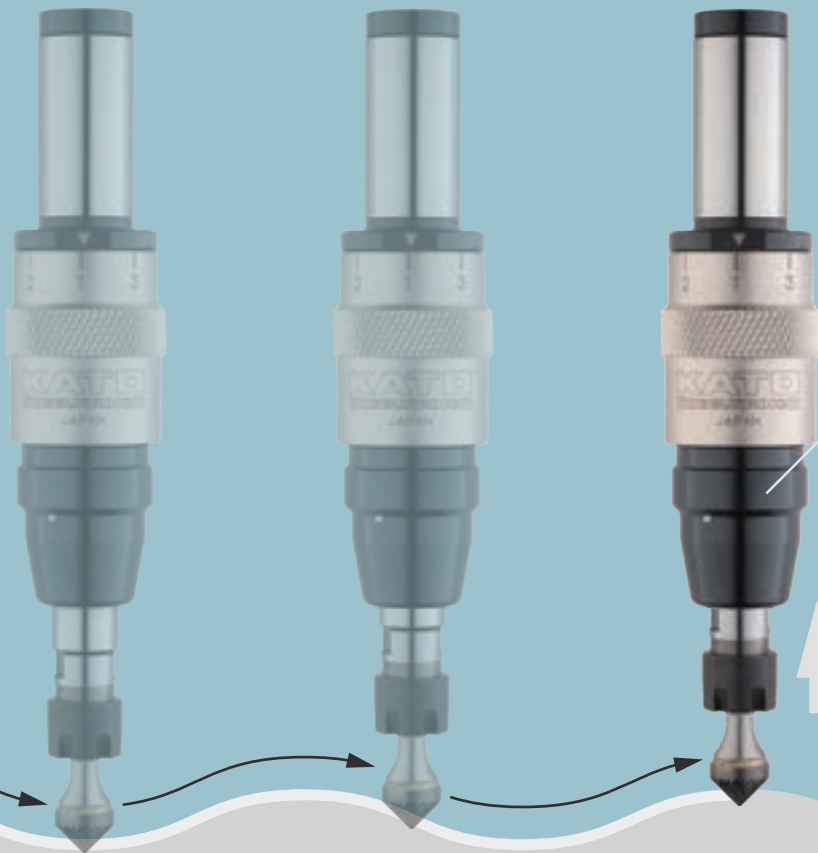

Deburring from by hands  
to the machine



**Dust-proof cover**

**10mm compression**

- The tool follows the shape of the workpiece
- Prevent shaving too much
- Easy CNC programming
- Stable deburring volume

## Load setting 4 stage switching

You can change the compression load depending on the workpiece



Sample

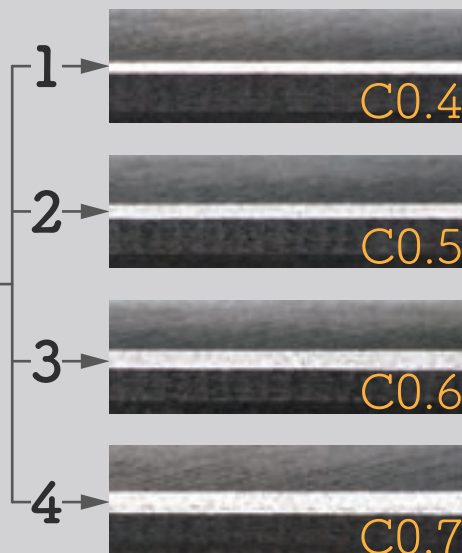

YouTube  
link →



Before

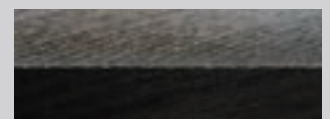

**Cutting condition**

FCD400

5,000[r/min]

1,500[mm/min]

# Specifications

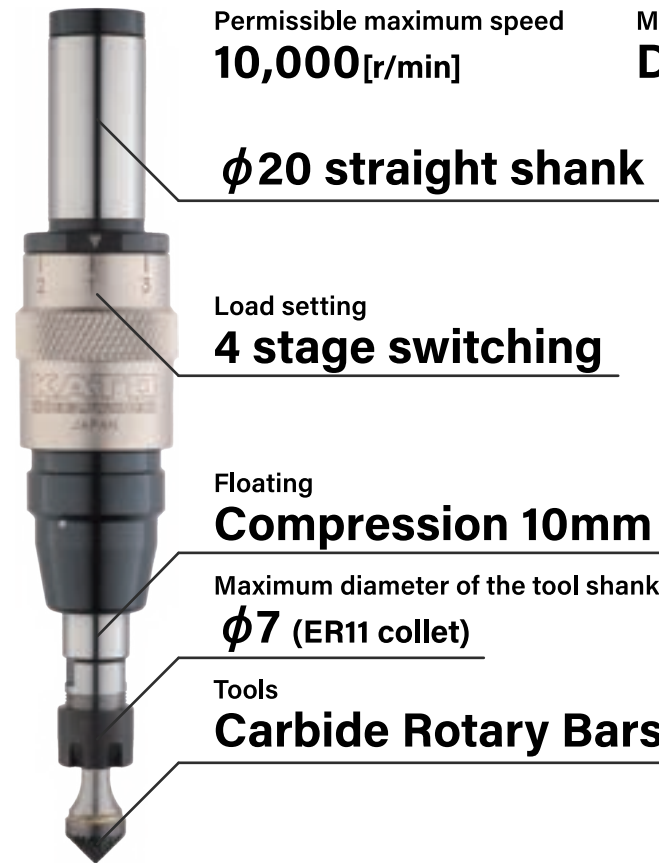

Permissible maximum speed  
**10,000[r/min]**

Machining condition  
**Dry cutting only**

**φ20 straight shank**

Load setting  
**4 stage switching**

Floating  
**Compression 10mm**

Maximum diameter of the tool shank  
**φ7 (ER11 collet)**

Tools  
**Carbide Rotary Bars, Brushes and etc.**



holding with a milling chuck

## Optional accessories



Collet  
**ER11**



Wrench  
**E11M**

# Dimensions

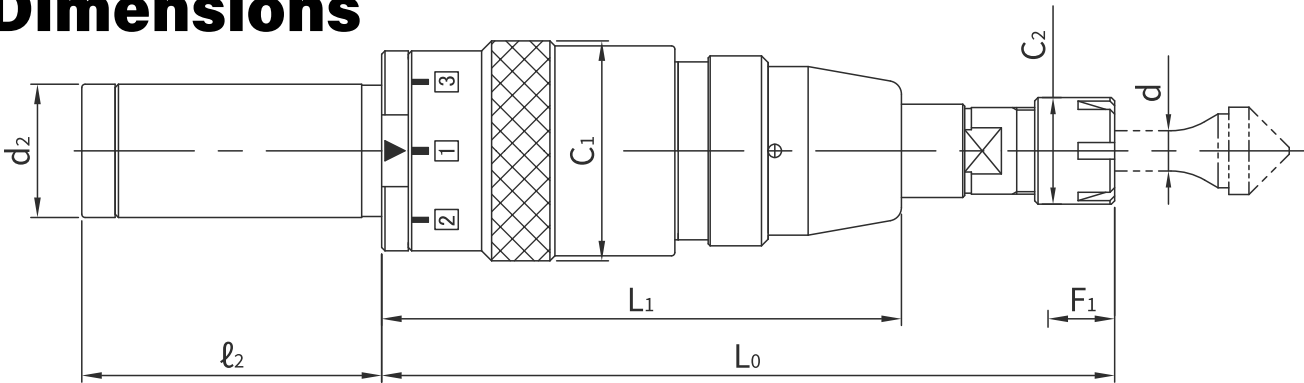

(mm)

Model	L <sub>0</sub>	L <sub>1</sub>	C <sub>1</sub>	C <sub>2</sub>	Compression F <sub>1</sub>	Shank		Tool Shank d	Weight[kg]
						d <sub>2</sub>	l <sub>2</sub>		
ST20-DBR7-SC	110	78	33	16	10	φ 20	45	φ 3 ~ φ 7	0.43

## KATO MFG.CO.,LTD.

2-65 Shinmachi, Hiratsuka, Kanagawa 254-0076 Japan

TEL : +81-463-36-1511

<https://kato-koki.com/eng/>